

# Steel Door Sets

## Hinged Fire / Security Doors



Fire rated doors designed to contain and prevent the spread of fire for a specified period of time. Available in latched and unlatched configurations. Sizes and hardware constraints vary between classifications.

The slim single rebate frame used as standard allows Fire Doors to be easily used instead of timber doors; as with our flush doors they are supplied fully assembled and finished which means that doors and frames can be installed in one visit without the need to make additional visits to install door blades and hardware and as our doors are supplied prefinished in a wide range of colours this also eliminates the need for site painting.

### **Door Leaf**

All fire resistant doors are custom made, to a maximum width of 1250mm as a single and 2600mm as a double. A maximum height of 2800mm in a single leaf. Infill panels to side or top can be provided as optional extras.

### **Thickness:**

48mm.

### **Material:**

1.2mm corrosion resistant Zintec/Aluzinc sheets as standard. Wide variety of colours and finishes available.

### **Infill:**

Self supporting resin-impregnated honeycomb core as standard, with the option of mineral wool or solid timber.



**BI-FOLD ROLFE LTD**  
*Industrial Door Specialist*

---

UNIT 4, CALCOT MOUNT, CALCOT LANE, CURDRIDGE, HAMPSHIRE SO32 2BN  
Tel: (01489) 780099 Fax: (01489) 780090  
E-Mail: [sales@bifoldrolfe.com](mailto:sales@bifoldrolfe.com) [www.bifoldrolfe.com](http://www.bifoldrolfe.com)

### Construction Door Leaf:

Door blade manufactured from two 1.2mm sheets lock formed together, by bonding two steel skins around a rigid core, using a no-weld construction. Flush Astragal to protect meeting style as standard on all doors.  
Note: Stock doors are fitted with a universal lock which can be replaced with a blanking plate.

### Construction Door Frame:

Folded from 1.6mm Zintec/Aluzinc. Screw and tab construction with 4no. adjustable fixing feet per jamb, variable subframe supplied as standard to accommodate site tolerance of -0/+30mm. The frame is fitted with 4no. Dog-bolt hinges as standard. A non-welded construction from two skins of Zintec folded around a rigid core.

### Sizes:

Doors are custom manufactured in 10mm increments for single openings 690mm to 1390mm and double openings 1290mm to 2600mm, at heights up to 2900mm.

### Stock:

Stock sizes are held in 50mm increments for single openings 690mm to 1390mm and double openings 1290mm to 2600mm, at a standard height of 2100mm. Contact our Sales office for special configurations and finishes.

### Profile

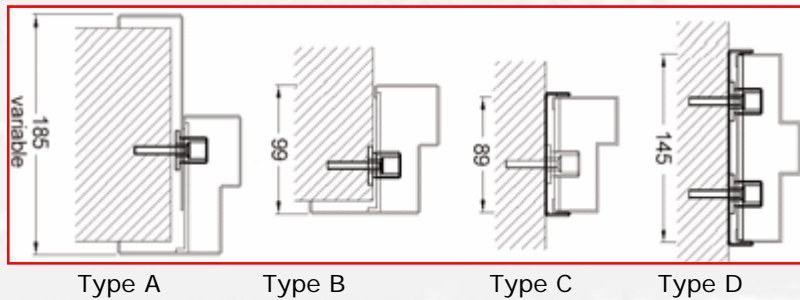

### Threshold

Standard: 15mm rebated threshold.  
Optional: 5mm driveable (DDA compliant).  
12.5mm 564A Aluminium (DDA compliant).

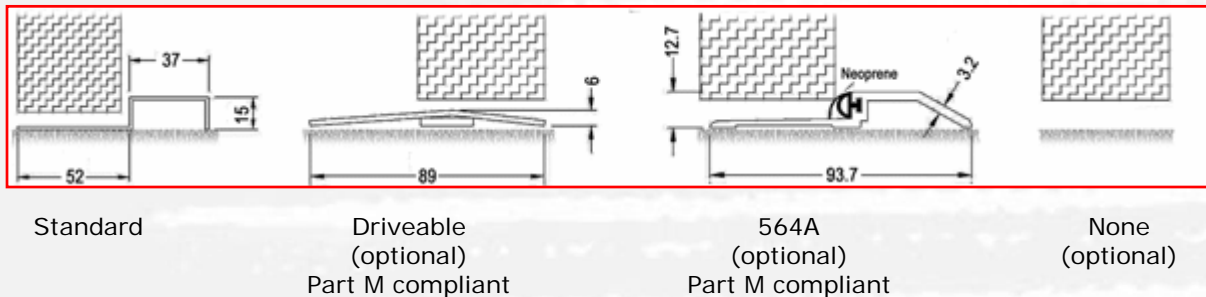

### FINISHES

Standard: Pre-primed steel (approximating to BS10A05 Goosewing Grey) requiring site painting.  
Optional: Polyester Powder Coating from standard colour range.  
PVC laminate from standard range. Woodgrain PVC laminate.  
Stainless steel, brushed, polished or patterned.



**BI-FOLD ROLFE LTD**  
*Industrial Door Specialist*

UNIT 4, CALCOT MOUNT, CALCOT LANE, CURDRIDGE, HAMPSHIRE SO32 2BN  
Tel: (01489) 780099 Fax: (01489) 780090  
E-Mail: [sales@bifoldrolfe.com](mailto:sales@bifoldrolfe.com) [www.bifoldrolfe.com](http://www.bifoldrolfe.com)

**VISION PANELS**

**Guidance Notes:**

To comply with Part M of the Building Regulations 2004, doors across circulation routes should have visibility glazing. (Vision panels less than 50% of the total door area are exempt from Part L of the Building Regulations.)

**Fire Assessment:**

Under the BRE Assessment the following rules apply:

Maximum panel size 637x592mm (0.377m<sup>2</sup>)

No vision panel to be fitted within 200mm of any door leaf edge.

Options : Standard glazing is 6mm GWPP Safety (up to 2hrs. integrity).

Alternative options include 6mm Firelite Clear Ceramic Glass (up to 4hrs. integrity).

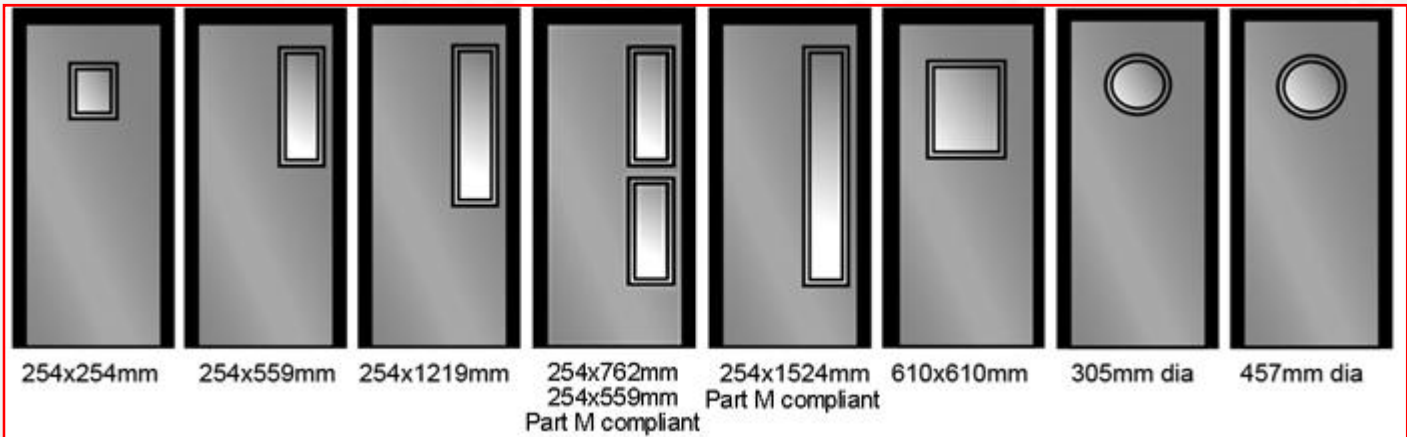
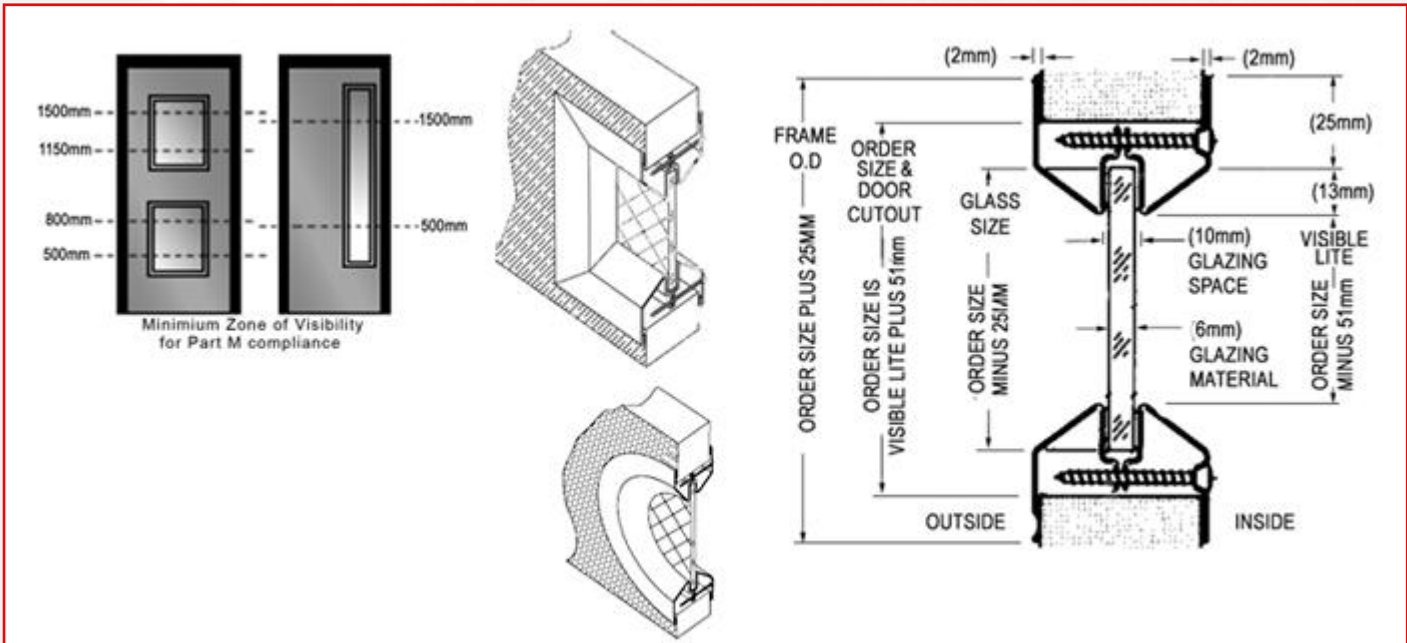

**BI-FOLD ROLFE LTD**  
*Industrial Door Specialist*

UNIT 4, CALCOT MOUNT, CALCOT LANE, CURDRIDGE, HAMPSHIRE SO32 2BN  
 Tel: (01489) 780099 Fax: (01489) 780090  
 E-Mail: sales@bifoldrolfe.com www.bifoldrolfe.com

**LOUVRE PANELS**

Construction: FD60 & FD120 the Louvre panel has moveable steel blades which can be closed manually. The blades are also closed by a fail-safe fusible link set to melt at 160°.

FD240 (optionally FD60 & FD120) the panel is constructed of 2 separate steel Louvre panels fitted on either side of an intumescent fire block core. Fire Assessment: Under the BRE Assessment the following rules apply: Maximum panel size 610x610mm (0.372m<sup>2</sup>).

No Louvre panel to be fitted within 200mm of any door leaf edge.  
The Louvre panel top should be not more than 1000mm from floor level.

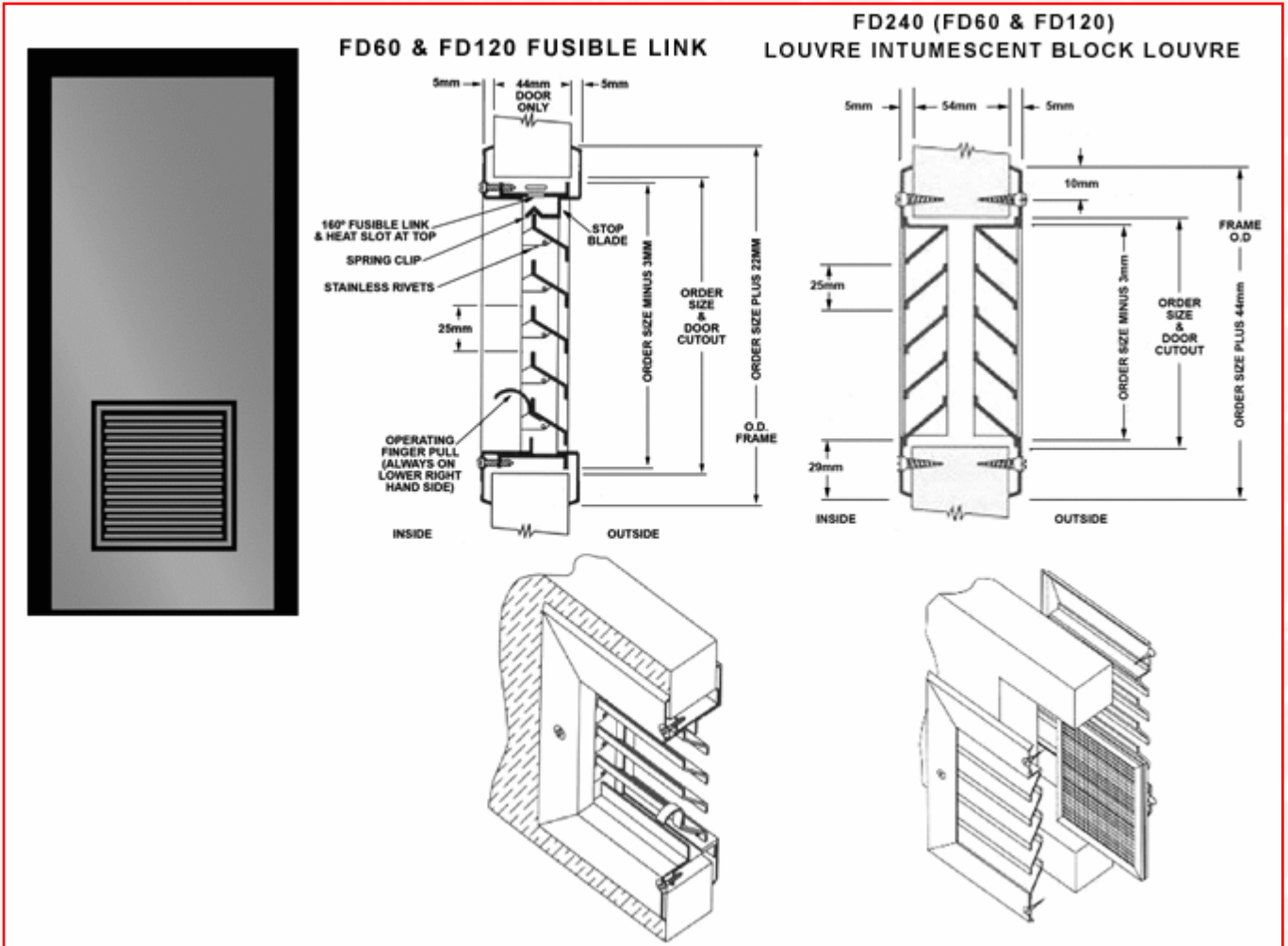

**BI-FOLD ROLFE LTD**  
*Industrial Door Specialist*

UNIT 4, CALCOT MOUNT, CALCOT LANE, CURDRIDGE, HAMPSHIRE SO32 2BN  
Tel: (01489) 780099 Fax: (01489) 780090  
E-Mail: sales@bifoldrolfe.com www.bifoldrolfe.com